



 **BOTTARINI**

# KA

**Screw compressors  
2,2 - 7,5 Kw**



# KA

a new series of technologically advanced compressors, resulting from an accurate research and development process.

The result is an extremely noiseless compressor, environmentally friendly thanks to a reduced current consumption and the use of easily recyclable materials.

## NOISELESS

Very low noise levels have been reached (61-66db) thanks to a correct conveying of the air flow which allows the upmost silence, while respecting the environment and the user, as well as an optimized cooling.

## OPERATING ONLY WHEN NEEDED

The Start/Stop operating mode allows to operate the compressor only when needed, with a consequent reduction in energy consumption.

All KA compressors are complete with a Start/Stop key and direct activation of the hour counters and the pressure gauge.



## AIR BASIC 2 CONTROL UNIT (for PREMIUM KA 4-5-7 versions)

This electronic control unit is easy to use and allows the compressor to be fully controlled. It manages and controls, in fact, the star-delta motor, the rotation direction, the ON OFF operation with automatic discharge of pressure when the machine is stopped, the remote controls, all protection and warning alarms, as well as a complete series of messages connected with ordinary maintenance.

## AIR/OIL SEPARATION SYSTEM

Higher reliability and reduction of tubes and connections thanks to the use of an integrated block, that provides for air-oil separation and filtering. The effectiveness of filtering ensures a very reduced level of residual oil, equal to 3 ppm max. This block houses oil filter, oil separation filter, minimum pressure valve, safety valve, oil thermostat and check valve.



## SUCTION VALVE

Higher fluid dynamic efficiency has been achieved thanks to the new suction valve with vertical configuration. In this way, the sucked air is conveyed through a straight line, thus ensuring a lower load loss. This valve features an ON/OFF operation, with discharging of pressure when the machine is stopped. This type of valve was specially studied to use a limited number of components, which ensure long duration with minimum maintenance.

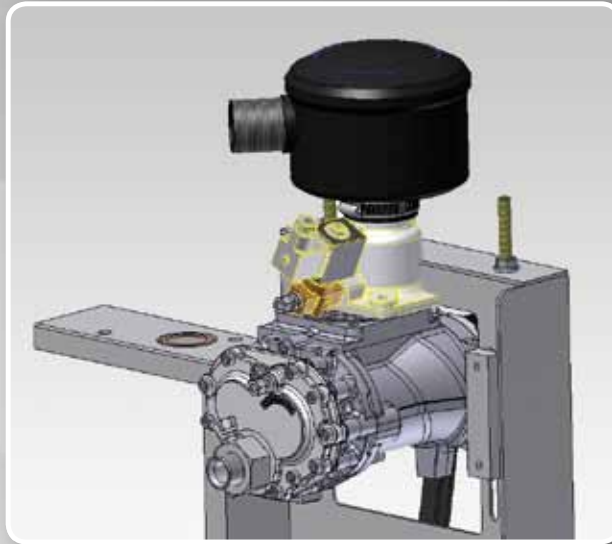

## REDUCED MAINTENANCE COSTS

The panelled structure allows an easy access from any side. Components subject to ordinary maintenance (air cartridge, oil cartridge, oil separator, belts, oil loading and discharge) can be all reached from the same side.

## TRANSMISSION

The already tested belt transmission with balanced pulleys in cast iron and bevel bearing is installed. Belts are of top quality to ensure the utmost reliability and duration. The belt tensioning system has been simplified thanks to one single adjustment screw, which guarantees easier control and replacement operations.



## LOW NOISE LEVEL ENCLOSURE

It is composed of a rugged base covered with panels, for an easy handling of the system, and a panelled structure, entirely removable, for an easy access. The panels are internally coated with closed cell sound-absorbing material, lined with washable and oil and humidity resistant film. In spite of these highly technological characteristics, this material is easily disposable with no environmental impact.



# KA PACKAGE COMPRESSORS

## WITH COOLING CYCLE DRYER, FILTERS AND TANK.

Specially studied to be functional, the KA Package compressors can be easily and rapidly installed in any place. The basic version can be customized to meet the most stringent requirements, in order to achieve a functional system.

The ideal solution for an integrated compressor

### 5X1 = KA PACKAGE

1 Compressor 2 Dryer 3 Tank

4 Automatic discharger of dew 5 Kit of filters

### EDX REFRIGERANT DRIER

A guarantee of the best performances with minimum pressure losses • Dew point at 3 °C with ambient temperature of 25 °C (ISO 7183) • Cooler R134a, eco-compatible • Display of digital control unit: – Indication of the dew point – Additional way of energy saving – Display for maintenance – Memory of faults

### STANDARD EQUIPMENT

- Star/Delta start (Premium versions)
- Air Basic 2 control unit (Premium versions)
- Direct start-up
- Overload relay
- Start/Stop control key with pressure switch (KA2-KA5)
- Start/Stop push-button.
- On/Off main switch (Premium versions)
- IE2-IP55 electric motors, insulation class: F
- Oil level monitoring, inspection window
- Transmission belt
- Safety devices for:
  - Motor overheating
  - Compressor overheating, automatic stop at 110 °C
- Indicators of the operating conditions:
  - Pressure
  - Hour counter
- Cover with epoxy powder coating
- Oil thermostat
- First filling in factory
- AEON lubricator

### OPTIONAL

A series of Optionals are available in order to obtain the most complete and functional system in an integrated solution.

More specifically, it is possible to equip the KA Package compressors with a kit of filters with by-pass which guarantee that air is treated before entering the plant, thus reducing the creation of dew inside the network.

The second optional available is the automatic dew discharger for tanks, which, once installed and programmed, will periodically





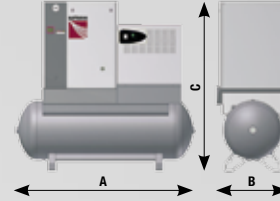
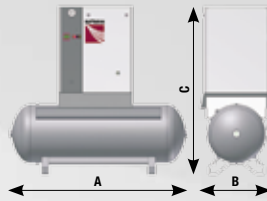
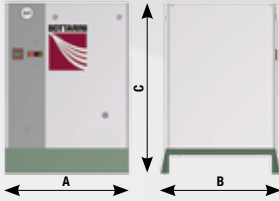

discharge the dew that might be present inside the tank.

Moreover, to protect the compressor when installed in particularly dusty rooms or, in any case, in not optimal locations, the KA systems can be equipped with Anti-dust panel, which guarantees a good filtering of the sucked cooling air.





## Technical data

     										Dimensions				
MOD.	REF.	m <sup>3</sup> /min	cfm	HP	KW	Bar	dB(A)	Tank	Volt/Hz	Weight	A	B	C	OUT BSP
KA 2	CC1026757B	0,24	8,48	3	2,2	10	61	#	VOLT 400/3/50	100	620	600	840	1/2"
KA 3	CC1026766B	0,36	12,72	4	3	10	61	#						
KA 4	CC1026767B	0,53	18,73	5,5	4	10	62	#						
KA 5	CC1026756B	0,67	23,67	7,5	5,5	10	66	#						
<b>KA TANK</b>														
KA 2/200	CC1026748B	0,24	8,48	3	2,2	10	61	200	VOLT 400/50/3	165	1450	600	1350	1/2"
KA 3/200	CC1026749B	0,36	12,72	4	3	10	61	200						
KA 4/200	CC1026750B	0,53	18,73	5,5	4	10	62	200						
KA 5/200	CC1026751B	0,67	23,67	7,5	5,5	10	66	200						
KA 2/270	CC1026758B	0,24	8,48	3	2,2	10	61	270	VOLT 400/50/3	205	1530	600	1400	1/2"
KA 3/270	CC1026759B	0,36	12,72	4	3	10	61	270						
KA 4/270	CC1026760B	0,53	18,73	5,5	4	10	62	270						
KA 5/270	CC1026761B	0,67	23,67	7,5	5,5	10	66	270						
KA 4/500	CC1026739B	0,53	18,73	5,5	4	10	62	500	VOLT 400/50/3	250	1850	680	1475	1/2"
KA 5/500	CC1026740B	0,67	23,67	7,5	5,5	10	66	500						
<b>KA PACKAGE</b>														
KA 2/EDX4/200	CC1026752B	0,24	8,48	3	2,2	10	61	200	VOLT 400/3/50	212	1450	600	1350	1/2"
KA 3/EDX4/200	CC1026753B	0,36	12,72	4	3	10	61	200						
KA 4/EDX6/200	CC1026754B	0,53	18,73	5,5	4	10	62	200						
KA 5/EDX9/200	CC1026755B	0,67	23,67	7,5	5,5	10	66	200						
KA 2/EDX4/270	CC1026762B	0,24	8,48	3	2,2	10	61	270	VOLT 400/3/50	252	1530	600	1400	1/2"
KA 3/EDX4/270	CC1026763B	0,36	12,72	4	3	10	61	270						
KA 4/EDX6/270	CC1026764B	0,53	18,73	5,5	4	10	62	270						
KA 5/EDX9/270	CC1026765B	0,67	23,67	7,5	5,5	10	66	270						
KA 4/EDX6/500	CC1026741B	0,53	18,73	5,5	4	10	62	500	VOLT 400/3/50	290	1858	680	1475	1/2"
KA 5/EDX9/500	CC1026742B	0,67	23,67	7,5	5,5	10	66	500						

\* Air flow rate measured according to standards ISO 1217, ed.4, ANNEX E – 2009 and test code / Pneurop/Cagi PN 2 CPTC2 at the following working pressure: 7 bar versions at 7,5/8/8,5 bar; 9 bar versions at 10 bar; 12 bar versions at 13 bar.

\*\* Sound pressure level measured according to standards ISO 2151 and ISO 3744 at 1 m distance in a free field.

WARNING: in particular indoor installation environments, the noise may increase by as much as 6\_10 dB(A) due to sound reflections against the walls.

The manufacturer may change the above-mentioned technical specifications without prior notice.

# KA 2-5

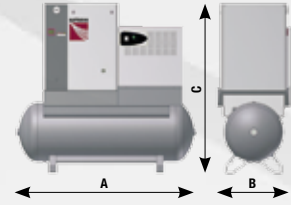
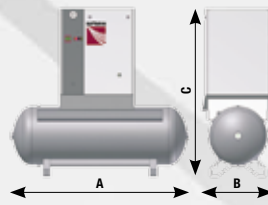
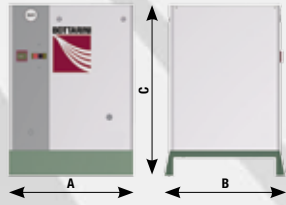

## Technical data

										Dimensions				
MOD.	REF.	m <sup>3</sup> /min	cfm	HP	KW	Bar	dB(A)	Tank	Volt/Hz	Weight	A	B	C	OUT BSP
KA 7 - 8 bar	CC1053384	1,05	37	10	7,5	8	67	#	VOLT 400/50/3	155	680	600	1000	3/4"
KA 7 - 10 bar	CC1053385	0,93	33	10	7,5	10	67	#						
KA 7 - 13 bar	CC1053386	0,74	26	10	7,5	13	67	#						
<b>KA TANK</b>														
KA 7 / 270	CC1053387	1,05	37	10	7,5	8	67	270	VOLT 400/50/3	260	1540	600	1560	3/4"
KA 7 / 270	CC1053388	0,93	33	10	7,5	10	67	270						
KA 7 / 270	CC1053389	0,74	26	10	7,5	13	67	270						
KA 7 / 500	CC1053390	1,05	37	10	7,5	8	67	500	VOLT 400/50/3	305	1950	680	1680	3/4"
KA 7 / 500	CC1053391	0,93	33	10	7,5	10	67	500						
KA 7 / 500	CC1053393	0,74	26	10	7,5	13	67	500						
<b>KA PACKAGE</b>														
KA 7/EDX12/270	CC1053394	1,05	37	10	7,5	8	67	270	VOLT 400/50/3	300	1540	600	1560	3/4"
KA 7/EDX12/270	CC1053395	0,93	33	10	7,5	10	67	270						
KA 7/EDX12/270	CC1053396	0,74	26	10	7,5	13	67	270						
KA 7/EDX12/500	CC1053397	1,05	37	10	7,5	8	67	500	VOLT 400/50/3	345	1950	680	1680	3/4"
KA 7/EDX12/500	CC1053398	0,93	33	10	7,5	10	67	500						
KA 7/EDX12/500	CC1053399	0,74	26	10	7,5	13	67	500						

\* Air flow rate measured according to standards ISO 1217, ed.4, ANNEX E – 2009 and test code / Pneurop/Cagi PN 2 CPTC2 at the following working pressure: 7 bar versions at 7,5/8/8,5 bar; 9 bar versions at 10 bar; 12 bar versions at 13 bar.

\*\* Sound pressure level measured according to standards ISO 2151 and ISO 3744 at 1 m distance in a free field.

WARNING: in particular indoor installation environments, the noise may increase by as much as 6\_10 dB(A) due to sound reflections against the walls.

The manufacturer may change the above-mentioned technical specifications without prior notice.

# KA 7



## Maintenance is as easy as ever.

### FAST AND EASY SERVICE

These compressors are designed to ensure easy access to maintenance points. All panels on the structure can be easily removed to allow full access to all service points. Also, the limited number of moving parts reduces service costs.

### SERVICE NETWORK

Our large network of approved Gardner Denver dealers is always at your service to ensure the smooth running of your compressor. Gardner Denver can ensure the swift supply of replacement parts to respond to different system needs.

### AFTER-SALES SERVICE

Gardner Denver offers a full range of after-sales services to fulfil all client needs. Using original spare parts will allow customers to save time and money in the long run.



## Product range

KS .....



KSA .....



KDV .....



GDP .....



Accessories .....



Piston  
Compressors .....

