



Adsorption Dehumidifier DehuTech DT-400

Dehumidifying capacity
at 20°C / 60%RH

1,5 kg/h

Dry air flow-rate

400 m³/h



- Washable rotor
- No desiccant carry-over
- Stainless steel casing
- Direct driven fans
- Self-control PTC air heater
- Air filters
- Connection of control equipment
- Option: air condenser
- Easy installation and maintenance
- Long lifetime

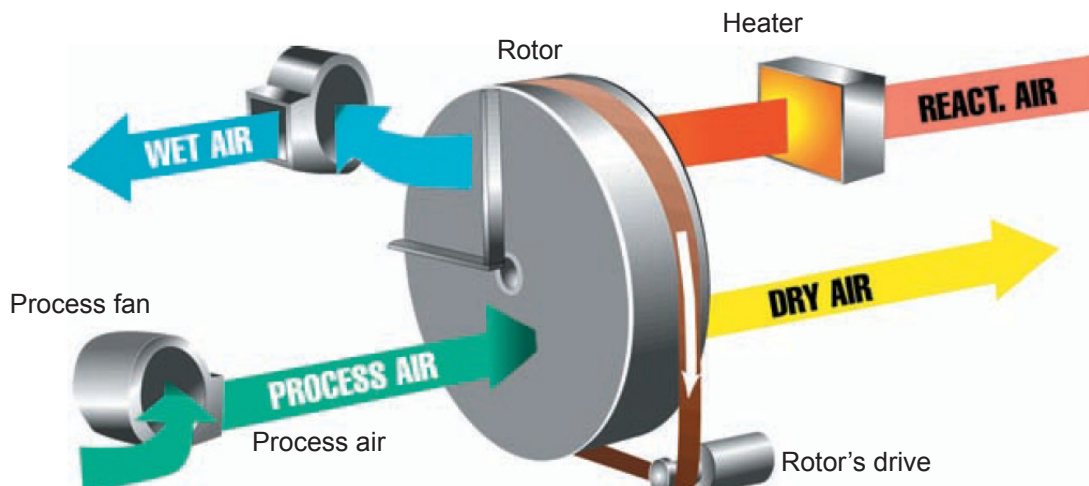

TECHNICAL DATA

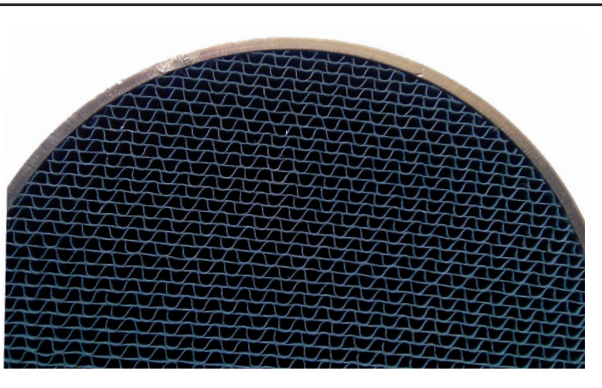

Dehumidifier, type	DT-400
Nominal capacity *	1,5 kg/h
Dry air flow-rate**	400 m ³ /h
Wet air flow-rate **	120 m ³ /h
Total power	2,3 kW
Supply fuse 230VAC	10 A
Rotor regeneration ***	E
Weight	28 kg
Max. noise level	62,2 dB(A)

* Valid for 20°C and 60%RH. For other condition the capacity must be recalculated according to diagram - see below.
 ** Flow related to air density 1.20 kg/m³.
 *** E: electric, G: NG, S: steam, W: hot water

CAPACITY DIAGRAM

at Inlet:
 $x_p = 9,0$ g/kg
 $t_p = +20^\circ\text{C}$

at Outlet:
 $x_T = 6$ g/kg
 $t_T = 20 + 9,9^\circ\text{C} = +29,9^\circ\text{C}$

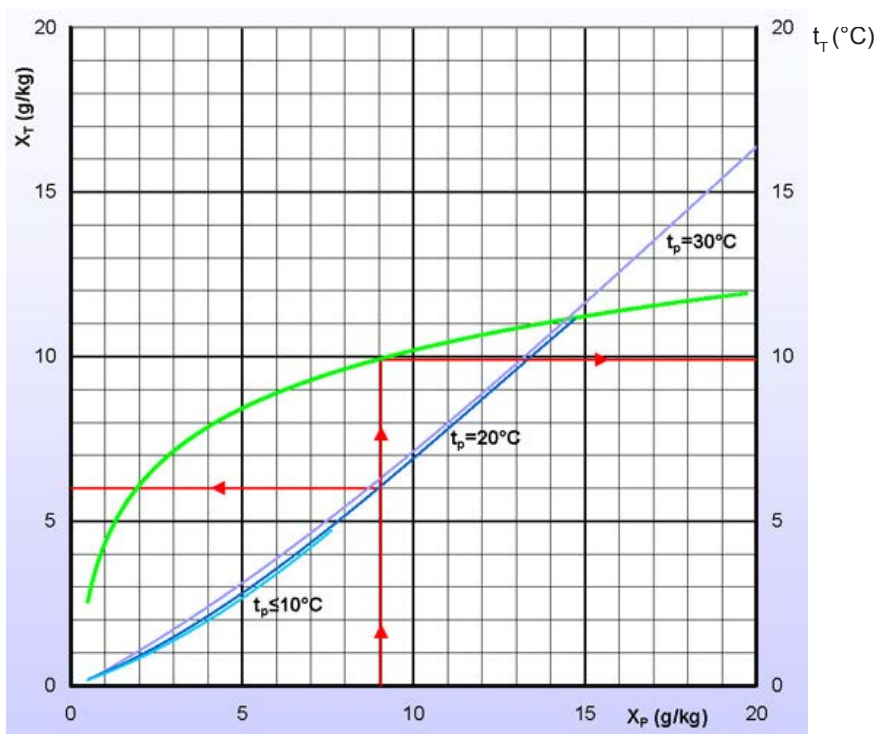

DIMENSIONS

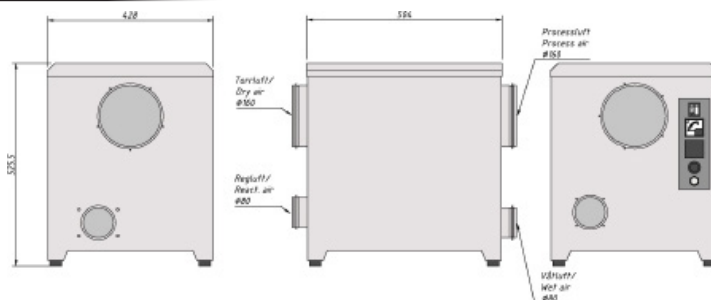

FILCO, spol. s r.o.
 Dvorská 464/103
 CZ-503 11 Hradec Králové
 Tel: +420 495 436 233
 info@filco.cz
 www.filco.cz



DehuTech AB
 Enhagsslingan 23,
 S-187 40 Täby, Sweden
 Tel.: +46 8792 04 08
 Fax: +46 8792 55 59
 info@dehutech.com
 www.dehutech.com