



Audit of Compressed Air & Gas Quality and Consumption



Brief Overview



Why to analyse?



Determining the compressed air consumption and other parameters to reveal the true operating parameters that are crucial for the choice and design of concrete solutions. Absolutely the most informative value have long-term measurements, which record all the data not only during peak demand, but also outside of it - in the nights, weekends, etc..

Application:

- During design of the renovation or construction of new system such measurements confirm or complement design tasks
- Analysis any size between small appliances up to large and extensive compressed air distribution systems
- Determination of the losses due to air leakage(s)
- Determination of air velocity can discover the causes pressure loss
- The same analysis can also be performed on the distribution of nitrogen and other inert gases
- For compressed air saving design (filtration, drying, oil capture, aerosol)

Benefits:

- Variable connection to the pipe diameter up to DN250
- Installation of the measuring apparatus can be made during operation without depressurization system
- Data logger allows long-term measurements even of a few weeks
- Easy data transfer to PC and fast processing

Estimated parameters:

- Flow-rate Q (m³/h - acc. ISO 1217)
- Temperature T (°C)
- Pressure p (barg)
- Pressure dew point PDP (°C)
- Content (oil, aerosol, hydrocarbons)*

Requirements on site:

- Power supply 230VAC
- Ball valve G1/2" on the pipe - see the picture
- Minimum pipe diameter for correct measurement is 1/2"

Data ranges:

- Flow-rate: air speed 0 up to 185 m/s
- Temperature: -30°C up to +80°C
- Pressure: up to 16 barg
- Min. ØD: 15mm
- Pressure dew point: -100°C up to +40°C
- Datalogger data recordings: 10⁶ and more limited only by memory size SD card, Flash disc, LAN
- Content of hydrocarbons: 0.003 to 10 mg/m³ *

Results:

- Time profile of measured parameters (Q, T, p, PDP, oil)
- Hourly consumption of air
- Total amount of consumed air
- Statistics - minimum, maximum, mean, etc.

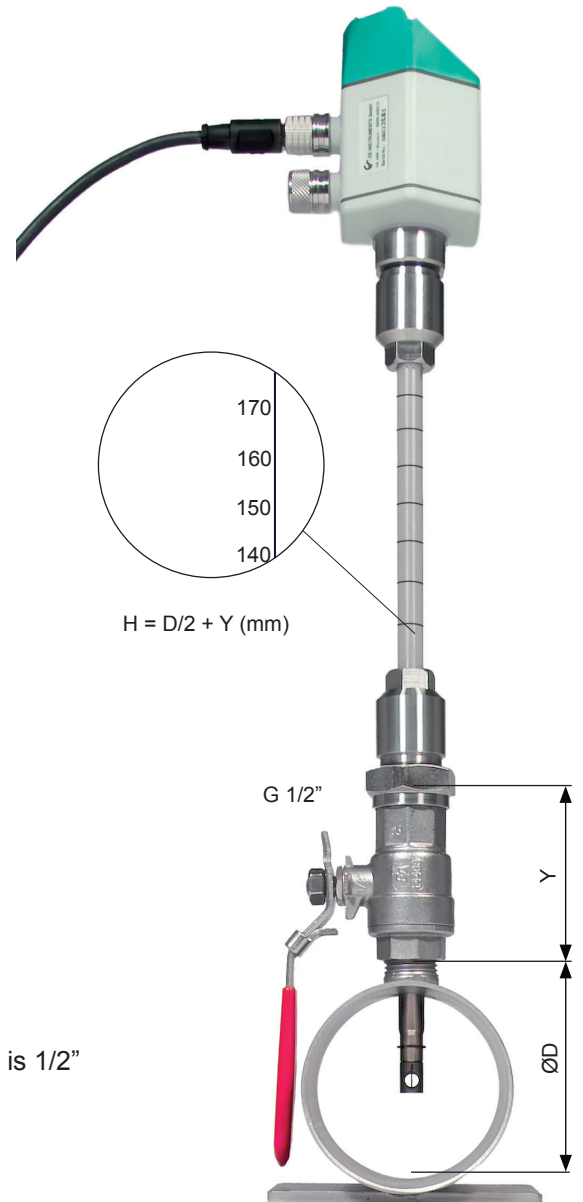

* compressed air must be dry (TRB + 3 ° C or lower)

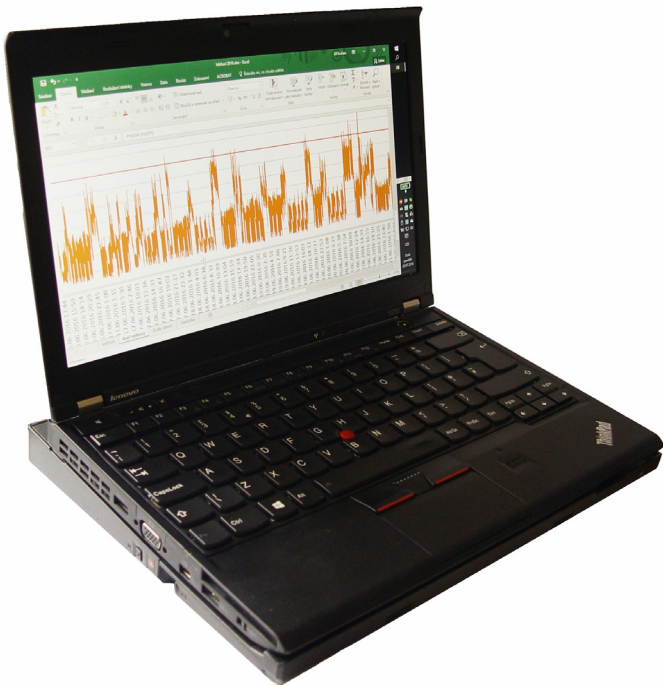

Advanced technology tailor-made ...

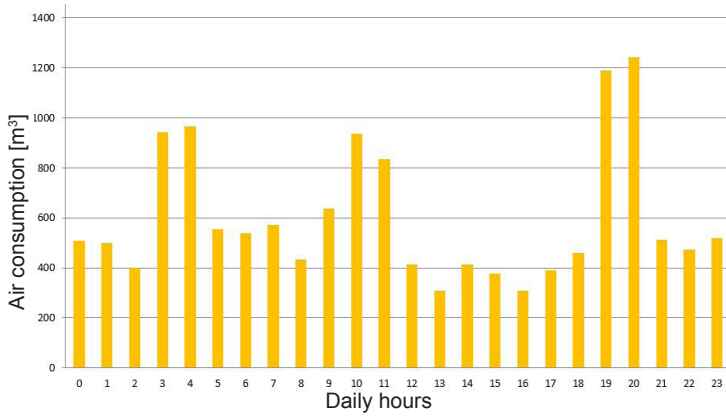

Oil content

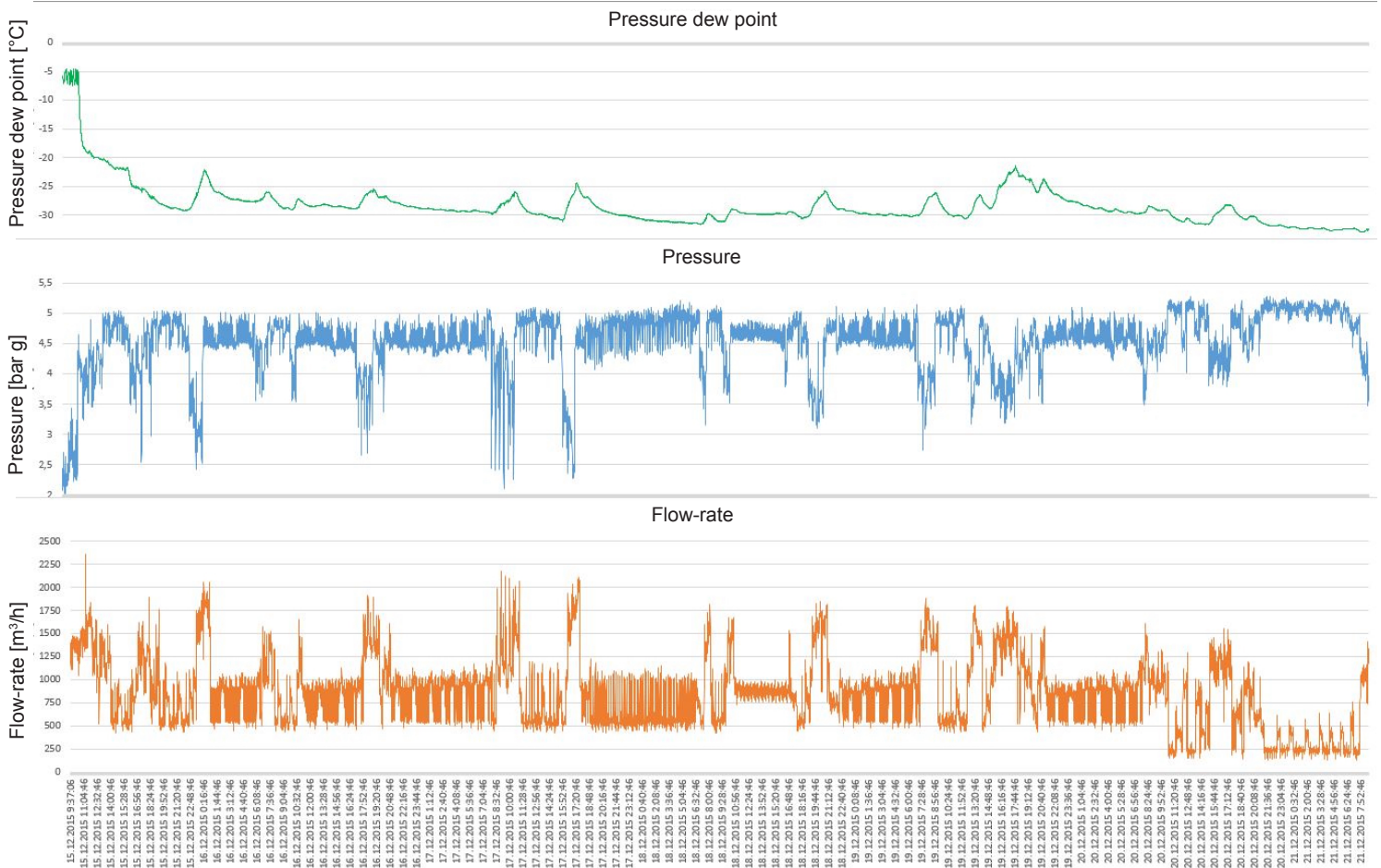
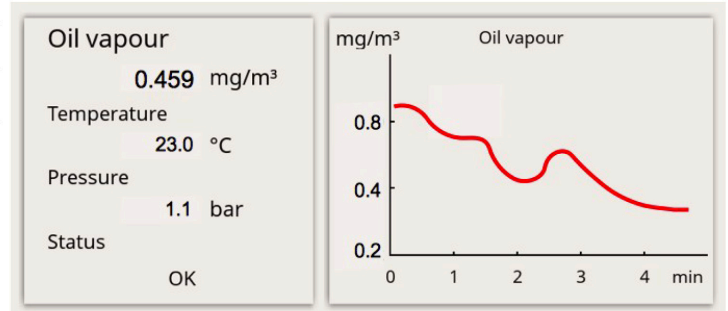

FILCO®, spol. s r.o.
 Dvorská 464/103
 CZ-503 11 Hradec Králové
 Tel: +420 495 436 233
 info@filco.cz
 www.filco.cz

