

# OFAS – Oil Free Air System

OFAS HL 050 - OFAS HL 085

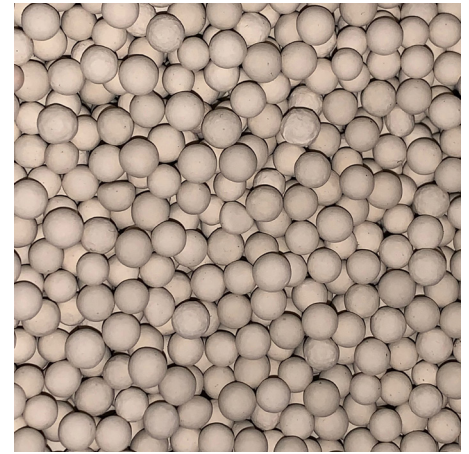

## Adsorption Dryers

Whether a compressed air user wants to control the growth of micro-organisms (essential for direct and in-direct contact applications in the food, beverage & pharmaceutical industries), ensure air used for critical applications / instrumentation is free from water contamination or has external piping where low ambient temperature can cause condensation, adsorption dryers are the go to dryer technology.

There are many different adsorption dryer technologies available and whilst they all reduce water from the compressed air in the same way, they differ in the way they regenerate the desiccant material.

## Heatless Adsorption Dryers

The simplest and most common method used to regenerate the adsorbent desiccant material is the 'heatless' method (so called as it does not use heat for desiccant regeneration).

Using a proportion of the clean, dry process air for regeneration, heatless dryers typically have the lowest capital costs of all adsorption dryer types (due to the simplicity of the heatless design).

Being very robust and having fewer components, they typically have the lowest maintenance cost of all the adsorption technologies.

Heatless dryers are available to suit all compressed air flow rates from small to large, whereas the more complicated regeneration methods are often only available for higher flow rates due to cost and complexity of the designs.



## Advantages

- Parker OFAS dryers provide a constant outlet dewpoint in accordance with ISO8573-1 classes 1, 2 or 3 for water vapour
- Parker OFAS dryers provide an outlet dewpoint which inhibits the growth of micro-organisms (allowing their efficient reduction using filtration)
- Parker OFAS dryers use clean, dry purge air for regeneration, eliminating any risk of damage to the adsorption bed or re-contamination of the downstream compressed air
- Parker OFAS dryer performance has been tested in accordance with ISO7183, the international standard for compressed air dryer testing
- The dewpoint performance of Parker OFAS dryers has been 3rd party validated by Lloyds Register to ISO8573-1 air purity classifications
- No heat is used for regeneration; therefore, no insulation is required and loss of dewpoint on column changeover due to inefficient cool down is eliminated
- Parker FBP dryers include Parker OIL-X General Purpose & High Efficiency Coalescing pre-filtration, Oil Vapour Reduction Stage and General Purpose Dry Particulate post filtration as standard
- Parker OFAS dryers provide Technically Oil Free Air to ISO8573-1 Class 0 and Class 1 for total oil due to the inclusion of an oil vapour reduction stage
- Full feature electronic control with dewpoint display and Energy Saving Technology fitted as standard



ENGINEERING YOUR SUCCESS.

## Dryer Performance

Dryer Models	Dewpoint (Standard)		ISO8573-1:2010 Classification (Standard)	Dewpoint (Option 1)		ISO8573-1:2010 Classification (Option 1)	Dewpoint (Option 2)		ISO8573-1:2010 Classification (Option 2)
	°C	°F		°C	°F		°C	°F	
OFAS HL	-40	-40	Class 2.2.0	-70	-100	Class 2.1.0	-20	-4	Class 2.3.0

ISO8573-1 Classifications when used with Parker domnick hunter OIL-X pre / post filtration

## Technical Data

Dryer Models	Minimum Operating Pressure		Maximum Operating Pressure		Minimum Operating Temperature		Maximum Operating Temperature		Maximum Ambient Temperature		Electrical Supply (Standard)	Electrical Supply (Optional)	Thread Type	Noise Level dB(A)
	bar g	psi g	bar g	psi g	°C	°F	°C	°F	°C	°F				
OFAS HL 050 ~ 085	4	58	16	232	5	41	50	122	55	131	85 - 265V 1ph 50/60Hz	24V DC	BSPP or NPT	<75

## Flow Rates

Model	Pipe Size BSPP or NPT	Inlet Flow Rate			
		L/s	m³/min	m³/hr	cfm
OFAS HL 050	½"	15	0.92	55	32
OFAS HL 055	½"	19	1.17	70	41
OFAS HL 060	½"	25	1.50	90	53
OFAS HL 065	½"	31	1.84	110	65
OFAS HL 070	¾"	42	2.51	150	88
OFAS HL 075	1"	51	3.09	185	109
OFAS HL 080	1"	61	3.67	220	129
OFAS HL 085	1 ½"	83	5.01	300	177

Stated flows are for operation at 7 bar (g) (102 psi g) with reference to 20°C, 1 bar (a), 0% relative water vapour pressure. For flows at other pressures, apply the correction factors shown below.

## Product Selection & Correction Factors

For correct operation, compressed air dryers must be sized using for the maximum (summer) inlet temperature, maximum (summer) ambient temperature, minimum inlet pressure, required outlet dewpoint and maximum flow rate of the installation.

To select a dryer, first calculate the MDC (Minimum Drying Capacity) using the formula below then select a dryer from the flow rate table above with a flow rate equal to or above the MDC.

$$\text{Minimum Drying Capacity} = \text{System Flow} \times \text{CFIT} \times \text{CFAT} \times \text{CFMIP} \times \text{CFOD}$$

### CFIT - Correction Factor Maximum Inlet Temperature

Maximum Inlet Temperature	°C	25	30	35	40	45	50
	°F	77	86	95	104	113	122
Correction Factor		1.00	1.00	1.00	1.04	1.14	1.37

### CFAT - Correction Factor Maximum Ambient Temperature

Maximum Ambient Temperature	°C	25	30	35	40	45	50
	°F	77	86	95	104	113	122
Correction Factor		1.00	1.00	1.00	1.00	1.00	1.00

### CFMIP - Correction Factor Minimum Inlet Pressure

Minimum Inlet Pressure	bar g	4	5	6	7	8	9	10	11	12	13	14	15	16
	psi g	58	73	87	100	116	131	145	160	174	189	203	218	232
Correction Factor		1.60	1.33	1.14	1.00	0.89	0.80	0.73	0.67	0.62	0.57	0.53	0.50	0.47

### CFOD - Correction Factor Outlet Dewpoint

Outlet Dewpoint	°C	-20	-40	-70
	°F	-4	-40	-100
Correction Factor		0.91	1.00	2.00

## Controller Functions

Dryer Models	Controller Function							
	Power On Indication	Visual Fault Indication	Dewpoint Display	EST - Energy Saving Technology	Filter Service Indicator	Dryer Service Indicator	Fault Relay: Power Loss Dewpoint Alarm Sensor Failure	4-20mA Dewpoint Re-transmission
OFAS HL	•	•	•	•	•	•	•	•

## Included Filtration

Model	Pipe Size BSPP or NPT	Dryer Inlet		Dryer Outlet		
		General Purpose Pre-filter	High Efficiency Filter	Oil Vapour Reduction Filter	General Purpose Dry Particulate Filter	High Efficiency Dry Particulate Filter
OFAS HL 050	½"	AOP015C	AAP015C	Included	AOP015C	-
OFAS HL 055	½"	AOP015C	AAP015C	Included	AOP015C	-
OFAS HL 060	½"	AOP020C	AAP020C	Included	AOP020C	-
OFAS HL 065	½"	AOP020C	AAP020C	Included	AOP020C	-
OFAS HL 070	¾"	AOP025D	AAP025D	Included	AOP025D	-
OFAS HL 075	1"	AOP025E	AAP025E	Included	AOP025E	-
OFAS HL 080	1"	AOP025E	AAP025E	Included	AOP025E	-
OFAS HL 085	1 ½"	AOP030G	AAP030G	Included	AOP030G	-

Filtration Performance	General Purpose Pre-filter	High Efficiency Filter	Oil Vapour Reduction Filter	General Purpose Dry Particulate Filter	High Efficiency Dry Particulate Filter
Filtration Grade	Grade AO	Grade AA	OVR	Grade AO	-
Filtration Type	Coalescing	Coalescing	Adsorption	Dry Particulate	-
Particle Reduction (inc water & oil aerosols)	Down to 1 micron	Down to 0.01 micron	N/A	Down to 1 micron	-
Maximum Remaining Oil Aerosol Content at 21°C	≤0.5 mg/m³ (≤0.5 ppm(w))	≤0.01 mg/m³ (≤0.01 ppm(w))	N/A	N/A	-
Maximum Remaining Oil Vapour Content at System Temperature	N/A	N/A	≤0.003 mg/m³ (≤0.003 ppm(w))	N/A	-
Filtration Efficiency	99.925%	99.9999%	N/A	99.925%	-

## Weights & Dimensions

Model	Pipe Size BSPP or NPT	Dimensions						Weight	
		Height (H)		Width (W)		Depth (D)		kg	lbs
		mm	ins	mm	ins	mm	ins		
OFAS HL 050	½"	1133	45	559	22	512	20.2	90	198
OFAS HL 055	½"	1313	52	559	22	512	20.2	97	214
OFAS HL 060	½"	1510	59	559	22	496	19.5	106	234
OFAS HL 065	½"	1660	65	559	22	496	19.5	112	247
OFAS HL 070	¾"	2020	80	559	22	496	19.5	132	291
OFAS HL 075	1"	1595	63	559	22	682	27	184	406
OFAS HL 080	1"	1745	69	559	22	682	27	196	432
OFAS HL 085	1 ½"	2105	83	559	22	682	27	232	511

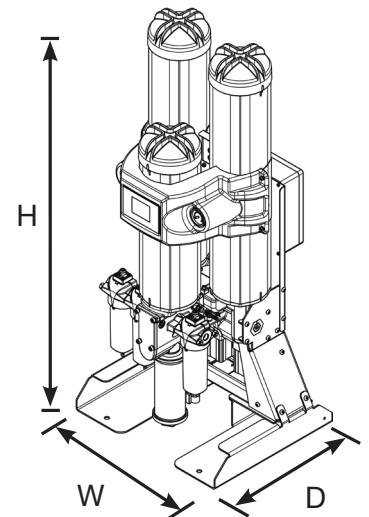

## Quality Assurance / IP Rating / Pressure Vessel Approvals

Development / Manufacture	ISO 9001 / ISO 14001
Ingress Protection Rating	IP55 Indoor Use Only
EU	Pressure vessel approved for fluid group 2 in accordance with the Pressure Equipment Directive 2014/68/EU
USA	Approval to ASME VIII Div. 1 not required
AUS	Approval to AS1210 not required
GUS	TR (formerly GOST-R)
<b>For use with Compressed Air Only</b>	

# Parker Worldwide

## Europe, Middle East, Africa

**AE – United Arab Emirates,**  
Dubai

Tel: +971 4 8127100  
parker.me@parker.com

**AT – Austria,** St. Florian

Tel: +43 (0)7224 66201  
parker.austria@parker.com

**AZ – Azerbaijan,** Baku

Tel: +994 50 2233 458  
parker.azerbaijan@parker.com

**BE/NL/LU – Benelux,**

Hendrik Ido Ambacht  
Tel: +31 (0)541 585 000  
parker.nl@parker.com

**BG – Bulgaria,** Sofia

Tel: +359 2 980 1344  
parker.bulgaria@parker.com

**BY – Belarus,** Minsk

Tel: +48 (0)22 573 24 00  
parker.poland@parker.com

**CH – Switzerland,** Etoy

Tel: +41 (0)21 821 87 00  
parker.switzerland@parker.com

**CZ – Czech Republic,** Klecany

Tel: +420 284 083 111  
parker.czechrepublic@parker.com

**DE – Germany,** Kaarst

Tel: +49 (0)2131 4016 0  
parker.germany@parker.com

**DK – Denmark,** Ballerup

Tel: +45 43 56 04 00  
parker.denmark@parker.com

**ES – Spain,** Madrid

Tel: +34 902 330 001  
parker.spain@parker.com

**FI – Finland,** Vantaa

Tel: +358 (0)20 753 2500  
parker.finland@parker.com

**FR – France,** Contamine s/Arve

Tel: +33 (0)4 50 25 80 25  
parker.france@parker.com

**GR – Greece,** Piraeus

Tel: +30 210 933 6450  
parker.greece@parker.com

**HU – Hungary,** Budaörs

Tel: +36 23 885 470  
parker.hungary@parker.com

**IE – Ireland,** Dublin

Tel: +353 (0)1 466 6370  
parker.ireland@parker.com

**IL – Israel**

Tel: +39 02 45 19 21  
parker.israel@parker.com

**IT – Italy,** Corsico (MI)

Tel: +39 02 45 19 21  
parker.italy@parker.com

**KZ – Kazakhstan,** Almaty

Tel: +7 7273 561 000  
parker.easteurope@parker.com

**NO – Norway,** Asker

Tel: +47 66 75 34 00  
parker.norway@parker.com

**PL – Poland,** Warsaw

Tel: +48 (0)22 573 24 00  
parker.poland@parker.com

**PT – Portugal**

Tel: +351 22 999 7360  
parker.portugal@parker.com

**RO – Romania,** Bucharest

Tel: +40 21 252 1382  
parker.romania@parker.com

**RU – Russia,** Moscow

Tel: +7 495 645-2156  
parker.russia@parker.com

**SE – Sweden,** Spånga

Tel: +46 (0)8 59 79 50 00  
parker.sweden@parker.com

**SK – Slovakia,** Banská Bystrica

Tel: +421 484 162 252  
parker.slovakia@parker.com

**SL – Slovenia,** Novo Mesto

Tel: +386 7 337 6650  
parker.slovenia@parker.com

**TR – Turkey,** Istanbul

Tel: +90 216 4997081  
parker.turkey@parker.com

**UA – Ukraine,** Kiev

Tel: +48 (0)22 573 24 00  
parker.poland@parker.com

**UK – United Kingdom,** Warwick

Tel: +44 (0)1926 317 878  
parker.uk@parker.com

**ZA – South Africa,** Kempton Park

Tel: +27 (0)11 961 0700  
parker.southafrica@parker.com

## North America

**CA – Canada,** Milton, Ontario

Tel: +1 905 693 3000

**US – USA,** Cleveland

Tel: +1 216 896 3000

## Asia Pacific

**AU – Australia,** Castle Hill

Tel: +61 (0)2-9634 7777

**CN – China,** Shanghai

Tel: +86 21 2899 5000

**HK – Hong Kong**

Tel: +852 2428 8008

**IN – India,** Mumbai

Tel: +91 22 6513 7081-85

**JP – Japan,** Tokyo

Tel: +81 (0)3 6408 3901

**KR – South Korea,** Seoul

Tel: +82 2 559 0400

**MY – Malaysia,** Shah Alam

Tel: +60 3 7849 0800

**NZ – New Zealand,** Mt Wellington

Tel: +64 9 574 1744

**SG – Singapore**

Tel: +65 6887 6300

**TH – Thailand,** Bangkok

Tel: +662 186 7000

**TW – Taiwan,** Taipei

Tel: +886 2 2298 8987

## South America

**AR – Argentina,** Buenos Aires

Tel: +54 3327 44 4129

**BR – Brazil,** Sao Jose dos Campos

Tel: +55 800 727 5374

**CL – Chile,** Santiago

Tel: +56 2 623 1216

**MX – Mexico,** Toluca

Tel: +52 72 2275 4200

### EMEA Product Information Centre

Free phone: 00 800 27 27 5374

(from AT, BE, CH, CZ, DE, DK, EE, ES, FI, FR, IE, IL, IS, IT, LU, MT, NL, NO, PL, PT, RU, SE, SK, UK, ZA)

### US Product Information Centre

Toll-free number: 1-800-27 27 537

[www.parker.com/gsf](http://www.parker.com/gsf)



**FILCO**, spol. s r.o.  
Dvorská 464/103  
CZ-503 11 Hradec Králové  
Tel: +420 495 436 233  
[info@filco.cz](mailto:info@filco.cz)  
[www.filco.cz](http://www.filco.cz)