

CDAS - Clean Dry Air System

ATEX Group II Cat 2 Compliant

CDAS HL 050 ATEX – CDAS HL 085 ATEX

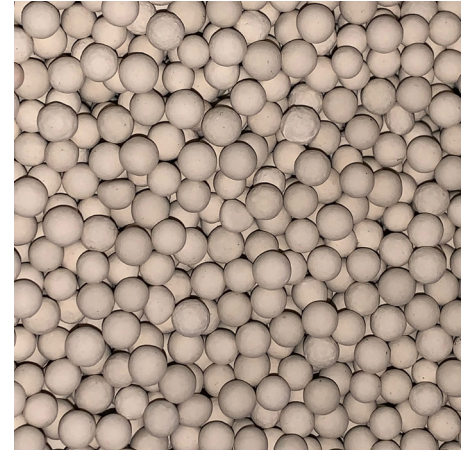

Adsorption Dryers

Whether a compressed air user wants to control the growth of micro-organisms (essential for direct and in-direct contact applications in the food, beverage & pharmaceutical industries), ensure air used for critical applications / instrumentation is free from water contamination or has external piping where low ambient temperature can cause condensation, adsorption dryers are the go to dryer technology.

There are many different adsorption dryer technologies available and whilst they all reduce water from the compressed air in the same way, they differ in the way they regenerate the desiccant material.

Heatless Adsorption Dryers

The simplest and most common method used to regenerate the adsorbent desiccant material is the 'heatless' method (so called as it does not use heat for desiccant regeneration).

Using a proportion of the clean, dry process air for regeneration, heatless dryers typically have the lowest capital costs of all adsorption dryer types (due to the simplicity of the heatless design).

Being very robust and having fewer components, they typically have the lowest maintenance cost of all the adsorption technologies.

Heatless dryers are available to suit all compressed air flow rates from small to large, whereas the more complicated regeneration methods are often only available for higher flow rates due to cost and complexity of the designs.



Advantages

- Parker CDAS ATEX dryers provide a constant outlet dewpoint in accordance with ISO8573-1 classes 1, 2 or 3 for water vapour
- Parker CDAS ATEX dryers provide an outlet dewpoint which inhibits the growth of micro-organisms (allowing their efficient reduction using filtration)
- Parker CDAS ATEX dryers use clean, dry purge air for regeneration, eliminating any risk of damage to the adsorption bed or re-contamination of the downstream compressed air
- Parker CDAS ATEX dryer performance has been tested in accordance with ISO7183, the international standard for compressed air dryer testing
- The dewpoint performance of Parker CDAS ATEX dryers has been 3rd party validated by Lloyds Register to ISO8573-1 air purity classifications
- No heat is used for regeneration; therefore, no insulation is required and loss of dewpoint on column changeover due to inefficient cool down is eliminated
- Parker CDAS ATEX dryers include Parker OIL-X General Purpose & High Efficiency Coalescing pre-filtration and General Purpose Dry Particulate post filtration as standard
- Parker CDAS ATEX dryers are fully pneumatic - no electrical connections required
- Parker CDAS ATEX dryers are compliant with ATEX Directive 2014/34/EU Group II Category 2 GD



ENGINEERING YOUR SUCCESS.

Dryer Performance

Dryer Models	Dewpoint (Standard)		ISO8573-1:2010 Classification (Standard)
	°C	°F	
CDAS HL ATEX	-40	-40	Class 2.2.2

ISO8573-1 Classifications when used with Parker domnick hunter OIL-X pre / post filtration

Technical Data

Dryer Models	Minimum Operating Pressure		Maximum Operating Pressure		Minimum Operating Temperature		Maximum Operating Temperature		Maximum Ambient Temperature		Electrical Supply	Thread Type	Noise Level
	bar g	psi g	bar g	psi g	°C	°F	°C	°F	°C	°F			dB(A)
CDAS HL ATEX	4	58	16	232	5	41	50	122	55	131	Not Applicable - Fully Pneumatic Operation	BSPP or NPT	<75

Flow Rates

Model	Pipe Size BSPP or NPT	Inlet Flow Rate			
		L/s	m³/min	m³/hr	cfm
CDAS HL 050 ATEX	½"	15	0.92	55	32
CDAS HL 055 ATEX	½"	19	1.17	70	41
CDAS HL 060 ATEX	½"	25	1.50	90	53
CDAS HL 065 ATEX	½"	31	1.84	110	65
CDAS HL 070 ATEX	¾"	42	2.51	150	88
CDAS HL 075 ATEX	1"	51	3.09	185	109
CDAS HL 080 ATEX	1"	61	3.67	220	129
CDAS HL 085 ATEX	1 ½"	83	5.01	300	177

Stated flows are for operation at 7 bar (g) (102 psi g) with reference to 20°C, 1 bar (a), 0% relative water vapour pressure. For flows at other pressures, apply the correction factors shown below.

Product Selection & Correction Factors

For correct operation, compressed air dryers must be sized using for the maximum (summer) inlet temperature, maximum (summer) ambient temperature, minimum inlet pressure, required outlet dewpoint and maximum flow rate of the installation.

To select a dryer, first calculate the MDC (Minimum Drying Capacity) using the formula below then select a dryer from the flow rate table above with a flow rate equal to or above the MDC.

Minimum Drying Capacity = System Flow x CFIT x CFAT x CFMIP x CFOD

CFIT - Correction Factor Maximum Inlet Temperature

Maximum Inlet Temperature	°C	25	30	35	40	45	50
	°F	77	86	95	104	113	122
Correction Factor		1.00	1.00	1.00	1.04	1.14	1.37

CFAT - Correction Factor Maximum Ambient Temperature

Maximum Ambient Temperature	°C	25	30	35	40	45	50
	°F	77	86	95	104	113	122
Correction Factor		1.00	1.00	1.00	1.00	1.00	1.00

CFMIP - Correction Factor Minimum Inlet Pressure

Minimum Inlet Pressure	bar g	4	5	6	7	8	9	10	11	12	13	14	15	16
	psi g	58	73	87	100	116	131	145	160	174	189	203	218	232
Correction Factor		1.60	1.33	1.14	1.00	0.89	0.80	0.73	0.67	0.62	0.57	0.53	0.50	0.47

CFOD - Correction Factor Outlet Dewpoint

Outlet Dewpoint	°C	-20	-40	-70
	°F	-4	-40	-100
Correction Factor		0.91	1.00	2.00

Controller Functions

Dryer Models	Controller Function							
	Power On Indication	Visual Fault Indication	Dewpoint Display	EST - Energy Saving Technology	Filter Service Indicator	Dryer Service Indicator	Fault Relay: Power Loss Dewpoint Alarm Sensor Failure	4-20mA Dewpoint Re-transmission
CDAS HL ATEX	Not Applicable - Fully Pneumatic Operation							

Included Filtration

Model	Pipe Size BSPP or NPT	Dryer Inlet		Dryer Outlet		
		General Purpose Pre-filter	High Efficiency Filter	Oil Vapour Reduction Filter	General Purpose Dry Particulate Filter	High Efficiency Dry Particulate Filter
CDAS HL 050 ATEX	½"	AOP015C	AAP015C	-	AOP015C	-
CDAS HL 055 ATEX	½"	AOP015C	AAP015C	-	AOP015C	-
CDAS HL 060 ATEX	½"	AOP020C	AAP020C	-	AOP020C	-
CDAS HL 065 ATEX	½"	AOP020C	AAP020C	-	AOP020C	-
CDAS HL 070 ATEX	¾"	AOP025D	AAP025D	-	AOP025D	-
CDAS HL 075 ATEX	1"	AOP025E	AAP025E	-	AOP025E	-
CDAS HL 080 ATEX	1"	AOP025E	AAP025E	-	AOP025E	-
CDAS HL 085 ATEX	1 ½"	AOP030G	AAP030G	-	AOP030G	-

Filtration Performance	General Purpose Pre-filter	High Efficiency Filter	Oil Vapour Reduction Filter	General Purpose Dry Particulate Filter	High Efficiency Dry Particulate Filter
Filtration Grade	Grade AO	Grade AA	-	Grade AO	-
Filtration Type	Coalescing	Coalescing	-	Dry Particulate	-
Particle Reduction (inc water & oil aerosols)	Down to 1 micron	Down to 0.01 micron	-	Down to 1 micron	-
Maximum Remaining Oil Aerosol Content at 21°C	≤0.5 mg/m ³ (≤0.5 ppm(w))	≤0.01 mg/m ³ (≤0.01 ppm(w))	-	N/A	-
Maximum Remaining Oil Vapour Content at System Temperature	N/A	N/A	-	N/A	-
Filtration Efficiency	99.925%	99.9999%	-	99.925%	-

Weights & Dimensions

Model	Pipe Size BSPP or NPT	Dimensions						Weight	
		Height (H)		Width (W)		Depth (D)		kg	lbs
		mm	ins	mm	ins	mm	ins		
CDAS HL 050 ATEX	½"	1133	45	559	22	490	19	76	168
CDAS HL 055 ATEX	½"	1313	52	559	22	490	19	84	185
CDAS HL 060 ATEX	½"	1510	59	559	22	490	19	93	205
CDAS HL 065 ATEX	½"	1660	65	559	22	490	19	100	220
CDAS HL 070 ATEX	¾"	2020	80	559	22	490	19	120	265
CDAS HL 075 ATEX	1"	1595	63	559	22	682	27	165	364
CDAS HL 080 ATEX	1"	1745	69	559	22	682	27	180	397
CDAS HL 085 ATEX	1 ½"	2105	83	559	22	682	27	210	463

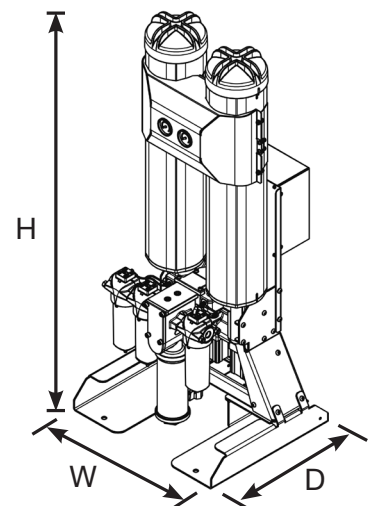

Quality Assurance / IP Rating / Pressure Vessel Approvals

Development / Manufacture	ISO 9001 / ISO 14001 / ATEX Directive 2014/34/EU Group II Category 2 & 3 GD
Ingress Protection Rating	IP55 Indoor Use Only
EU	Pressure vessel approved for fluid group 2 in accordance with the Pressure Equipment Directive 2014/68/EU
USA	Approval to ASME VIII Div. 1 not required
AUS	Approval to AS1210 not required
GUS	TR (formerly GOST-R)
For use with Compressed Air Only	



EMEA Product Information Centre

Free phone: 00 800 27 27 5374

(from AT, BE, CH, CZ, DE, DK, EE, ES, FI, FR, IE, IL, IS, IT, LU, MT, NL, NO, PL, PT, RU, SE, SK, UK, ZA)

US Product Information Centre

Toll-free number: 1-800-27 27 537

www.parker.com/gsf



FILCO, spol. s r.o.
Dvorská 464/103
CZ-503 11 Hradec Králové
Tel: +420 495 436 233
info@filco.cz
www.filco.cz