

OIL-X Coalescing & Dry Particulate Filters

Filtration Performance

Filtration Grade	Filter Type	Particle Reduction (inc water & oil aerosols)	Max. Remaining Oil Content at 21°C (70°F)	Filtration Efficiency	Initial Dry Differential Pressure	Initial Saturated Differential Pressure	Change Element Every	Precede with Filtration Grade
AO	Coalescing & Dry Particulate	Down to 1 micron	0.5 mg/m ³ 0.5 ppm(w)	99.925%	<70 mbar (1 psi)	<125 mbar (1.8 psi)	12 months	WS (for bulk liquid)
AA	Coalescing & Dry Particulate	Down to 0.01 micron	0.01 mg/m ³ 0.01 ppm(w)	99.9999%	<70 mbar (1 psi)	<125 mbar (1.8 psi)	12 months	AO

Technical Data

Filtration Grade	Filter Models	Minimum Operating Pressure		Maximum Operating Pressure		Minimum Operating Temperature		Maximum Operating Temperature	
		bar g	psi g	bar g	psi g	°C	°F	°C	°F
AO/AA	P010 - P055 (Float Drain)	1	15	16	232	2	35	80	176
	P010 - P055 (Manual Drain)	1	15	20	290	2	35	80	176
	P060 (Float Drain)	1	15	16	232	2	35	66	150
	P060 (Manual Drain)	1	15	20	290	2	35	100	212

Flow Rates

Model	Pipe Size	L/S	m ³ /min	m ³ /hr	cfm	Replacement Element	No.
Grade P010A	1/4"	10	0.6	36	21	P010	1
Grade P010B	3/8"	10	0.6	36	21	P010	1
Grade P010C	1/2"	10	0.6	36	21	P010	1
Grade P015C	1/2"	20	1.2	72	42	P015	1
Grade P020C	1/2"	30	1.8	108	64	P020	1
Grade P020D	3/4"	30	1.8	108	64	P020	1
Grade P025D	3/4"	60	3.6	216	127	P025	1
Grade P025E	1"	60	3.6	216	127	P025	1
Grade P030G	1 1/2"	110	6.6	396	233	P030	1
Grade P035G	1 1/2"	160	9.6	576	339	P035	1
Grade P040H	2"	220	13.2	792	466	P040	1
Grade P045I	2 1/2"	330	19.8	1188	699	P045	1
Grade P050I	2 1/2"	430	25.9	1548	911	P050	1
Grade P055I	2 1/2"	620	37.3	2232	1314	P055	1
Grade P055J	3"	620	37.3	2232	1314	P055	1
Grade P060K	4"	1000	60	3600	2119	P060	3

Stated flows are for operation at 7 bar (g) (102 psi g) with reference to 20°C, 1 bar (a), 0% relative water vapour pressure. For flows at other pressures, apply the correction factors shown below.

Product Selection & Correction Factors

To correctly select a filter model, the flow rate of the filter must be adjusted for the minimum operating (inlet) pressure at the point of installation.

1. Obtain the minimum operating (inlet) pressure and maximum compressed air flow rate at the inlet of the filter.
2. Select the correction factor for minimum inlet pressure from the CFMIP table (always round down e.g. for 5.3 bar, use 5 bar correction factor)
3. Calculate the minimum filtration capacity. Minimum Filtration Capacity = Compressed Air Flow Rate x CFMIP
4. Using the minimum filtration capacity, select a filter model from the flow rate tables above (filter selected must have a flow rate equal to or greater than the minimum filtration capacity).

CFMIP - Correction Factor Minimum Inlet Pressure

Minimum Inlet Pressure	bar g	1	2	3	4	5	6	7	8	9	10	11	12	13	14	15	16	17	18	19	20
	psi g	15	29	44	58	73	87	100	116	131	145	160	174	189	203	218	232	248	263	277	290
Correction Factor		2.65	1.87	1.53	1.32	1.18	1.08	1.00	0.94	0.88	0.84	0.80	0.76	0.73	0.71	0.68	0.66	0.64	0.62	0.61	0.59

When ordering a filter for pressures above 16 bar g (232 psi g), use a manual drain. Replace F with M in product code. e.g. AOP015BGF becomes AOP015BGM. Models 150 - 500 are not suitable for pressures above 16 bar g (232 psi g).

Filter Coding Example

Grade	Model	Pipe Size	Thread	Drain Option	Incident Monitor Option
AO	P & 3 digit code denotes filter housing size	Letter denotes pipe size	G = BSPP N = NPT	F = Float M = Manual	I = Indicator X = None
Example code					
AO	P010	A	G	F	I

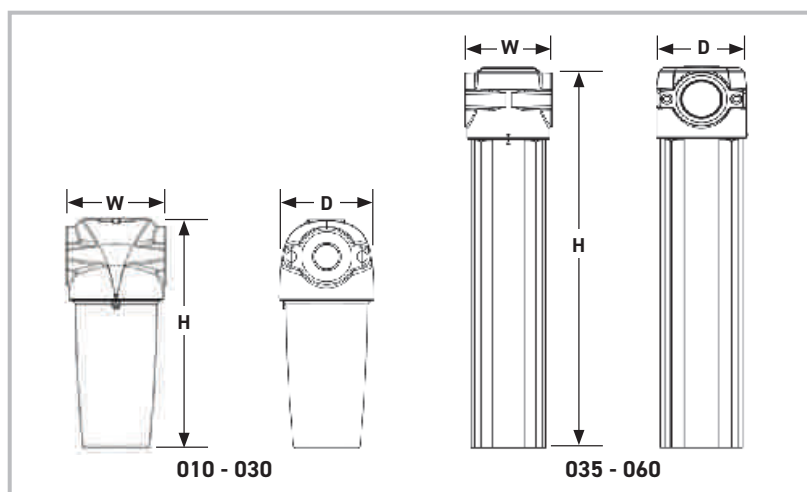

Weights & Dimensions

Model	Height (H)		Width (W)		Depth (D)		Weight	
	mm	ins	mm	ins	mm	ins	kg	lbs
010A	180	7.09	76	2.99	65	2.56	0.84	1.86
010B	180	7.09	76	2.99	65	2.56	0.84	1.84
010C	180	7.09	76	2.99	65	2.56	0.82	1.81
015C	238	9.37	89	3.5	84	3.31	1.16	2.55
020C	238	9.37	89	3.5	84	3.31	1.17	2.58
020D	238	9.37	89	3.5	84	3.31	1.44	3.19
025D	277	10.9	120	4.72	115	4.53	2.14	4.71
025E	277	10.9	120	4.72	115	4.53	2.69	5.92
030G	367	14.45	120	4.72	115	4.53	3.04	6.70
035G	440	20.9	164	6.46	157	6.18	6.90	15.21
040H	532	24.5	164	6.46	157	6.18	7.30	16.09
045I	532	24.5	164	6.46	157	6.18	7.10	15.65
050I	654	29.3	192	7.56	183	7.20	10.30	22.71
055I	844	36.8	192	7.56	183	7.20	15.90	33.05
055J	844	36.8	192	7.56	183	7.20	15.30	33.73
060K	847	33.3	420	16.54	282	11.10	44.50	98.11

Parker Catalogue Numbers (BSPP Models)

Model	Catalogue Number General Purpose Coalescing Filters	Catalogue Number General Purpose Dry Particulate Filters	Catalogue Number High Efficiency Coalescing Filters	Catalogue Number High Efficiency Dry Particulate Filters
P010A	AOP010AGFI	AOP010AGMI	AAP010AGFI	AAP010AGMI
P010B	AOP010BGFI	AOP010BGMI	AAP010BGFI	AAP010BGMI
P010C	AOP010CGFI	AOP010CGMI	AAP010CGFI	AAP010CGMI
P015C	AOP015CGFI	AOP015CGMI	AAP015CGFI	AAP015CGMI
P020C	AOP020CGFI	AOP020CGMI	AAP020CGFI	AAP020CGMI
P020D	AOP020DGFI	AOP020DGMI	AAP020DGFI	AAP020DGMI
P025D	AOP025DGFI	AOP025DGMI	AAP025DGFI	AAP025DGMI
P025E	AOP025EGFI	AOP025EGMI	AAP025EGFI	AAP025EGMI
P030G	AOP030GGFI	AOP030GGMI	AAP030GGFI	AAP030GGMI
P035G	AOP035GGFX	AOP035GGMX	AAP035GGFX	AAP035GGMX
P040H	AOP040HGFX	AOP040HGMX	AAP040HGFX	AAP040HGMX
P045I	AOP045IGFX	AOP045IGMX	AAP045IGFX	AAP045IGMX
P050I	AOP050IGFX	AOP050IGMX	AAP050IGFX	AAP050IGMX
P055I	AOP055IGFX	AOP055IGMX	AAP055IGFX	AAP055IGMX
P055J	AOP055JGFX	AOP055JGMX	AAP055JGFX	AAP055JGMX
P060K	AOP060KGFX	AOP060KGMX	AAP060KGFX	AAP060KGMX



FILCO[®], spol. s r.o. Dvorská
464/103
CZ-503 11 Hradec Králové
tel.: +420 495 436 233
info@filco.cz,
www.filco.cz